

## Wind Direction Sensor FVA 614



- Wind direction sensor for measuring the horizontal wind direction.
- Wind vane made from robust plastic, electronics in weather-resistant aluminum housing, rotating mechanism on friction bearings.
- A special labyrinth reliably protects without friction and guards against water penetrating into the housing.
- Electronically controlled heating for operation in winter conditions to prevent bearings and external rotating parts from freezing.

### Technical Data

Measuring range:	0 to 360°
Accuracy:	±5°
Resolution:	11.25° (5 bit Gray code)
Measuring principle:	optoelectronically (slotted disk)
Sensor power supply:	9–30VDC through ALMEMO® device
Heating:	24VAC/DC max. 20W
Operative range:	-30 to +70 °C, with heating
Cable:	12m long, LiYCY 6 x 0.25mm <sup>2</sup>

Connection:	Adapter cable with ALMEMO® connector including supply cable for heating (length 1.5 m, free ends) A mains supply unit must be provided by the user on site.
Installation:	e.g. pole tube with holding thread PG21 / drilling 29mm Ø
Weight	1100 g

### Type

Wind vane including ALMEMO® connector (0–2V) with 12m cable

### Order no.

FVA614

### Accessories for wind direction and wind velocity sensors

### Order no.

Cross-arm for separate wind direction and wind velocity sensors inclusive assembly utilities for mast Ø 48 to 102 mm

ZB9015TC

Lightning protection rod

ZB9015BS

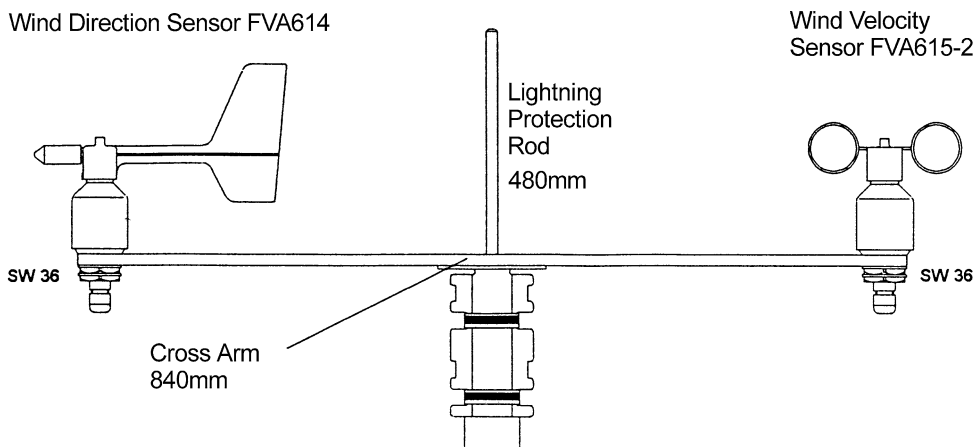

## Wind Velocity Sensor FVA 615 2



- Wind velocity sensor for measuring the horizontal wind velocity.
- Cup-type made from robust plastic, electronics in weather-resistant aluminum housing, rotating mechanism on friction bearings.
- A special labyrinth reliably protects without friction and guards against water penetrating into the housing.
- Electronically controlled heating for operation in winter conditions to prevent bearings and external rotating parts from freezing.

### Technical Data

Measuring range:	0.5 to 50m/s	Connection:	Adapter cable with ALMEMO® connector including supply cable for heating (length 1.5 m, free ends) A mains supply unit must be provided by the user on site.
Accuracy:	±0.5m/s ±3% of meas. value	Installation:	e.g. pole tube with holding thread PG21 / drilling 29mm Ø
Resolution:	0.1m/s	Weight	750 g
Measuring principle:	optoelectronically (slotted disk)		
Sensor power supply:	9–30VDC through ALMEMO® device		
Heating:	24VAC/DC max. 20W		
Operative range:	-30 to +70 °C, with heating		
Cable:	12m long, LiYCY 6 x 0.25mm <sup>2</sup>		

### Type

Cup-type anemometer including ALMEMO® connector (0–2V) with 12m cable

### Order no.

FVA6152