

TECHNICAL DATA SHEET

MT SERIES
INCLINED LIQUID COLUMN
PORTABLE MANOMETERS



The MT range of inclined liquid column portable manometers, developed and manufactured by KIMO, are particularly recommended for those in the heating trade for checking pressures in chimney flues, combustion chambers, filters...

- Easy to carry.
- Safety reservoir enabling momentaneous overshooting of the scale.
- Zero adjustment by moving the slide strip.
- Integrated spirit level for adjusting horizontality.
- Equipped with valve connectors, magnetic fixations, support with base plate.
- Can be used for measuring speeds with Pitot tube.
- Comes with connecting sleeves, bottle of liquid and travelling case.

MEASUREMENT RANGE

REFERENCE	MEASUREMENT RANGE		SENSITIVITY SCALE for 1 mm CE or 0.04 In.WG	RESOLUTION
	mm CE	In.WG		
MT 10	0-10	0-0.4	9.2 mm	0.2 mm CE or 0.01 In.WG
MT 40	0-40	0-1.6	4 mm	1 mm CE or 0.04 In.WG
MT 80	0-80	0-3.2	2 mm	1 mm CE or 0.04 In.WG
MT 100	0-100	0-4	1.4 mm	1 mm CE or 0.04 In.WG

CHARACTERISTICS

- Recommended range of use : +5 to 30°C.
- Possible range of use : -30 to 60°C.
- Maximum static pressure : 6 bars.
- Manometer body : transparent 15 mm thick Altuglas.
- Liquid column : entirely bored in the solid block, Ø 4 mm.
- Graduated slide strip : transparent Altuglas. Cross-section 20x2 mm.
- Zero adjustment by moving the graduated slide strip, travel 12 mm. Fixed in place via milled, nickel-plated brass screw.
- Horizontal positioning via integrated spirit level and milled, nickel-plated brass adjusting screw.
- Manometric liquid : VOLT 1S oil - density 1.86 at 20°C.
- Reservoir capacity : 20 ml.
- Connection : on valve connectors in nickel-plated brass Ø 6.2 mm neoprene tubes with connecting sleeves.

DIMENSIONS

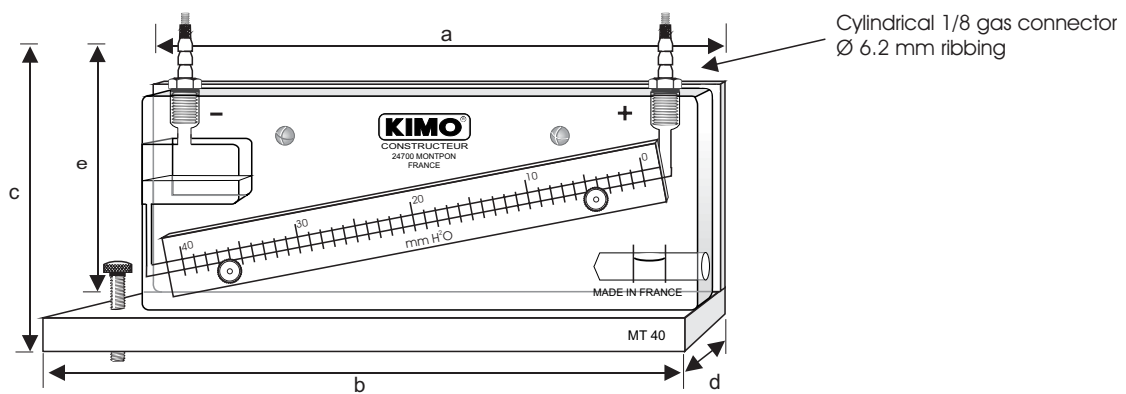

REFERENCE	a	b	c	d	e	Weight
MT 10	181 mm	196 mm	92 mm	37 mm	79 mm	760 g
MT 40	193 mm	208 mm	93 mm	37 mm	80 mm	800 g
MT 80	189 mm	203 mm	116 mm	37 mm	103 mm	820 g
MT 100	175 mm	190 mm	129 mm	37 mm	115 mm	840 g

MOUNTING

Place the manometer on a horizontal surface or a vertical partition wall by using the magnetic fixations. Set horizontality by using the integrated level and the milled adjusting screw. Unscrew the connector on the reservoir and slacken the milled wheel on the other connector by one turn. Slowly pour the manometric liquid to zero point on the graduation. Remount the connector without overtightening. Connect the manometer with the tube provided to the pressure or depression source to be checked.

NOTE :

- For a pressure measurement : connect the tube to the left-hand connector (+).
- For a depression measurement : connect the tube to the right-hand connector (-).
- For a differential pressure measurement : connect the highest pressure to the left-hand connector (+) and the lowest pressure to the right-hand connector (-).

MAINTENANCE : MT manometers require no special maintenance other than simply changing the reading liquid once a year.

www.kimo.fr

EXPORT DEPARTMENT

BP 48. Bld de Beaubourg - Emerainville
F-77312 MARNE LA VALLEE CEDEX 2 - FRANCE
Tel : 33. 1. 60. 06. 69. 25
Fax : 33. 1. 60. 06. 69. 29
e-mail : kimo.export@kimo.fr



Distributed by :