



- Designed specifically measurement of luminance at the tunnel portal or within the tunnel
- CIE Approved measurement of L20
- Variable viewing angle within a range of 10 to 40° available
- Silicon photo diode, V_{λ} filtered for spectral response
- Rugged 316L stainless steel construction
- Heated window and enclosure with IP66 protection rating
- Optional wash-wipe facility available
- Choice of interface / comms protocols

The LUMIOS measures the level of luminance, or brightness, created by natural light at the tunnel entrance / exit to ensure that the visual perception of drivers will be maintained, both day and night, by avoiding sudden variations in lighting levels and potential “black hole effect” when entering and exiting a tunnel.

The LUMIOS uses a specially designed, highly light-sensitive photocell, filtered to provide a spectral response close to that of the average human eye, to react to changes in light levels at the entrance and exit to, as well as within, the tunnel environment. This reaction is virtually instantaneous. The light receptor measures the average luminance within a fixed viewing angle that can be set during manufacture within a range of 10 to 40°. The standard instrument has an acceptance angle of 20°, (as recommended by Commission Internationale de l’Eclairage, (C.I.E.), publication 88, 2004). The luminance measurement range is 0 - 10,000 cd/m², which can be scaled to suit customer requirements.

The LUMIOS is a self-contained intelligent analyser and the measurements are converted into an output signal of 0/2/4-20 mA (directly proportional to the luminance measurement) for hard wire connection and signal transmission to a host controller. The LUMIOS also comes with alarm relay contacts and Modbus serial communications protocol.

The LUMIOS has been designed to enable it to withstand extremes of weather conditions. The complete electronic system is contained within a water-proof, heated housing of powder coated steel with an IP66 protection rating.

The LUMIOS has an operating temperature range from -40°C to +50°C which ensures stable readings across all prevailing ambient temperature conditions.

Various optional extras are available such as, mounting brackets and wash-wipe systems, providing a solution for the most demanding specifications.

Specification:

Measurement Performance

No.	Parameter	Units	Min	Max	Comment
1	Detector				Silicon photo diode, V_{λ} filtered
2	Viewing Angle (FWHM)	Deg	10	40	1° steps (defined at time of order) 20° as standard
3	Measurement Range	cd/m ²	0	10,000	Can be scaled within this range
4	Resolution	cd/m ²		1	Display resolution
5	Accuracy	%	-3	+3	Better than
6	Damping	seconds	1	100	Default setting is 10s

Power

7	AC Input Voltage	Vac	85	264	Nominal 100-240Vac.
8	AC Input Frequency	Hz	47	63	Nominal 50-60Hz.
9	Power Consumption	W	6	10 50	Without wash wipe With wash wipe

Interface Options

10	Serial Outputs				ModBus RTU via RS485 (isolated) External USB
11	Analogue Outputs (one)	mA	0 / 2 / 4	20	Isolated and scalable (user selected)
12	Digital Relay Contacts (four)	A	0	1	@240Vac (signal levels and data valid)

Physical

13	Ingress Protection			IP66	
14	Operating Temperature	°C	-40	+50	
15	Operating Humidity	%		100	
16	Regulatory Compliance				2014/30/EU (Electromagnetic Radiation) 2014/35/EU (Low Voltage)
17	Materials				AISI/SAE 316L stainless steel
18	Dimensions	mm	463 x 162 x 122 463 x 162 x 184		Without optional wiper With optional wiper
19	Weight	kg		5.5 6.3	Without optional wiper With optional wiper
20	Warranty	Months	24		Return to base warranty. Extensions available

Dimensions (without wiper):

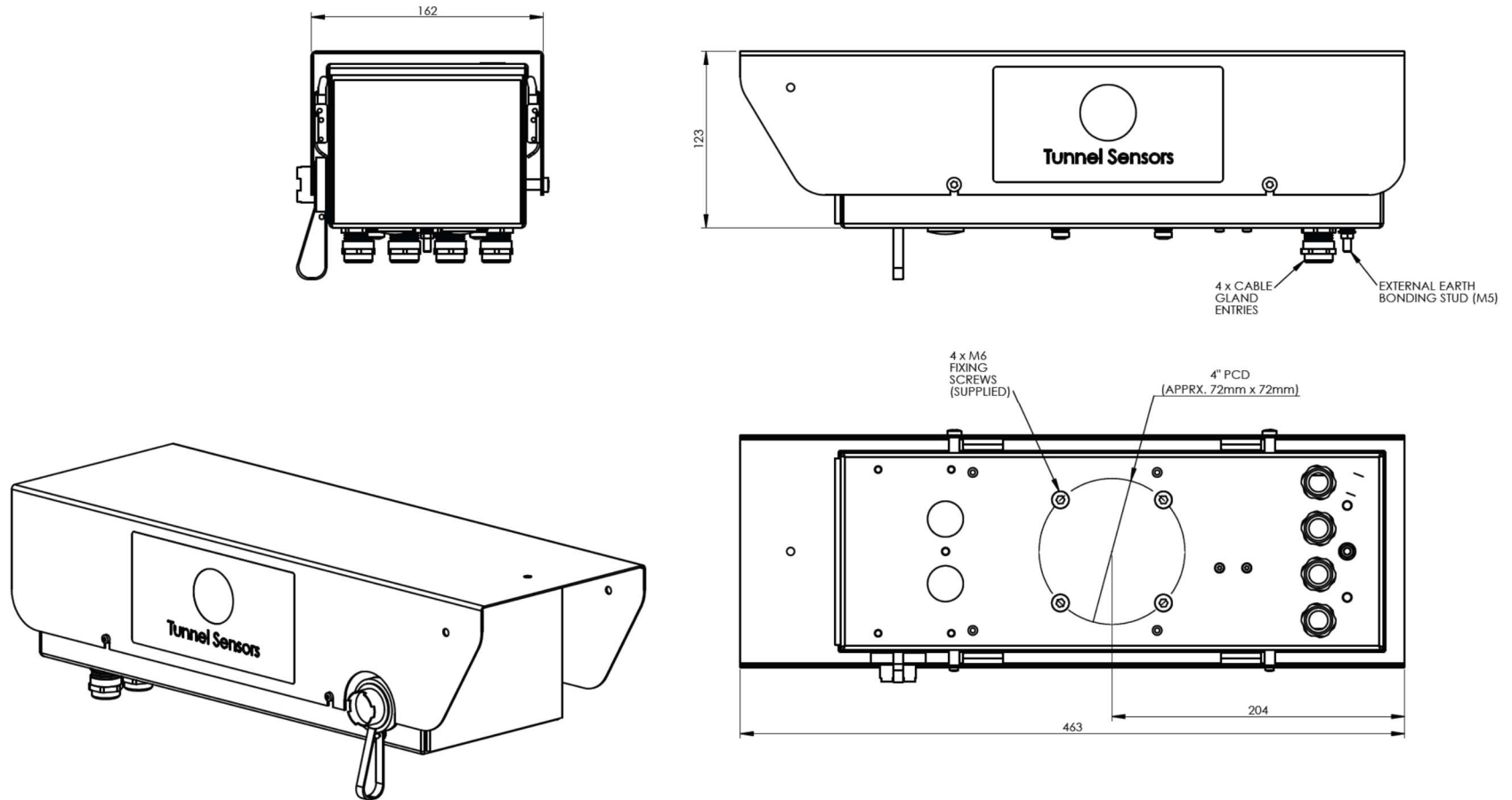

sales@tunnelsensors.com www.tunnelsensors.com

Specifications are subject to change without notice.
All images used are for illustrative purposes only. (C) 2020 Tunnel Sensors. All rights reserved.

Dimensions (with wiper):

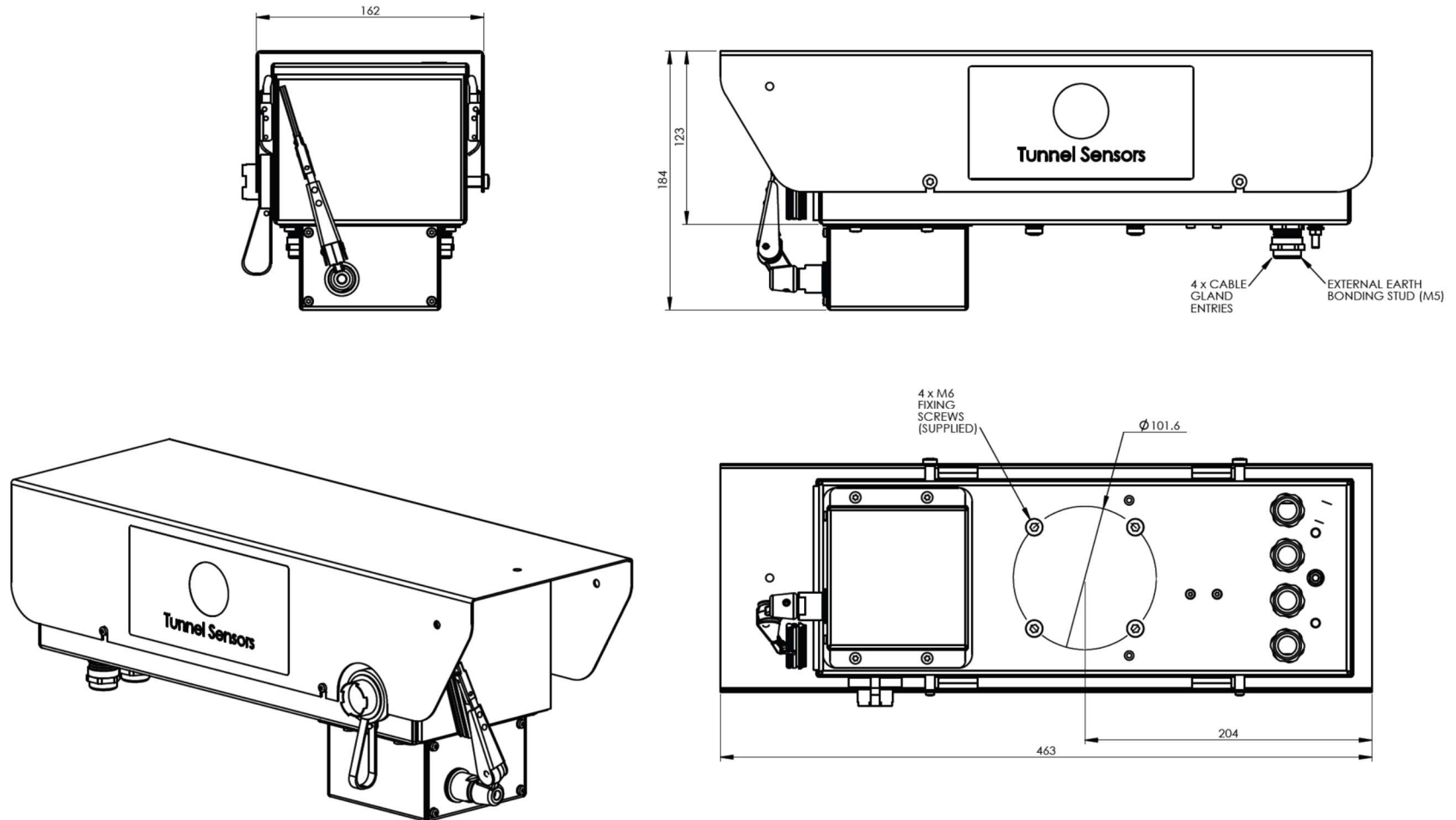

sales@tunnelsensors.com www.tunnelsensors.com

Specifications are subject to change without notice.
All images used are for illustrative purposes only. (C) 2020 Tunnel Sensors. All rights reserved.

Options & Accessories

Description	Order Code	Notes
	TSL-LUMIOS-MKIII	LUMIOS MkIII no wiper. Viewing angle: 20°
	TSL-LUMIOS-xx-MKIII	LUMIOS MkIII no wiper. (xx = viewing angle; 10 to 40°)
	TSL-LUMIOS-W-MKIII	LUMIOS MkIII with wiper. Viewing angle: 20°
	TSL-LUMIOS-Wxx-MKIII	LUMIOS MkIII with wiper. (xx = viewing angle; 10 to 40°)
Universal Bracket 	TSL-LU3-BRK-U	For mounting LUMIOS on a wall or a pole, with pan and tilt adjustment.
Wall Bracket 	TSL-LU3-BRK-W	For mounting LUMIOS on a wall, with pan and tilt adjustment.
Pole Top Bracket 	TSL-LU3-BRK-PT	For mounting LUMIOS on top of a pole or post, with pan and tilt adjustment.
Washer System 	TSL-LU3-WSH-5	+24Vdc, 5L reservoir, 8m head height, low fluid level output. Designed specifically for use with LUMIOS MkIII. This washer unit is connected to the LUMIOS using the 10m cable supplied, which provides power, command and control functionality.

<p>Over Voltage Protection Unit</p> 	<p>TSL-LU3-OVP</p>	<p>Provides additional protection against transient voltages in connected power, comms, and analogue output cables.</p>
---	--------------------	---

Note that the actual part may differ from the above representative pictures.